

NCP1082

Integrated PoE-PD & DC-DC Converter Controller with 9 V Auxiliary Supply Support

Introduction

The NCP1082 is a member of ON Semiconductor's Power over Ethernet Powered Device (PoE-PD) product family and represents a robust, flexible and highly integrated solution targeting demanding Ethernet applications. It combines in a single unit an enhanced PoE-PD interface fully supporting the IEEE 802.3af specification and a flexible and configurable DC-DC converter controller.

The NCP1082's exceptional capabilities enable applications to smoothly transition from non-PoE to PoE enabled networks by also supporting power from auxiliary sources such as AC power adapters and battery supplies, eliminating the need for a second switching power supply.

ON Semiconductor's unique manufacturing process and design enhancements allow the NCP1082 to deliver up to 13 W of regulated power to support PoE applications according to the IEEE 802.3af standard. This device leverages the significant cost advantages of PoE-enabled systems to a broad spectrum of products in markets such as VoIP phones, wireless LAN access points, security cameras, point of sales terminals, RFID readers, industrial ethernet devices, etc.

The integrated current mode DC-DC controller facilitates isolated and non-isolated fly-back, forward and buck converter topologies. It has all the features necessary for a flexible, robust and highly efficient design including programmable switching frequency, duty cycle up to 80 percent, slope compensation, and soft start-up.

The NCP1082 is fabricated in a robust high voltage process and integrates a rugged vertical N-channel DMOS with a low loss current sense technique suitable for the most demanding environments and capable of withstanding harsh environments such as hot swap and cable ESD events.

The NCP1082 complements ON Semiconductor's ASSP portfolio in communications and industrial devices and can be combined with other high-voltage interfacing devices to offer complete solutions to the communication, industrial and security markets.

Features

Powered Device Interface

- Flexible Auxiliary Power Supply Support
- 9 V Front, Rear and Direct Auxiliary Supply Connections
- Fully Supports IEEE 802.3af Standard
- Regulated Power Output up to 13 W
- Programmable Classification Current
- Adjustable Under Voltage Lock Out
- Programmable Inrush Current Limit

- Programmable Operational Current Limit up to 500 mA
- Over-temperature Protection
- Industrial Temperature Range -40°C to 85°C with Full Operation up to 150°C Junction Temperature
- 0.6 Ohm Hot-swap Pass-switch with Low Loss Current Sense Technique
- Vertical N-channel DMOS Pass-switch Offers the Robustness of Discrete MOSFETs with Integrated Temperature Control



ON Semiconductor®

<http://onsemi.com>

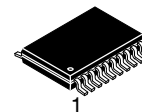

TSSOP-20 EP
DE SUFFIX
CASE 948AB

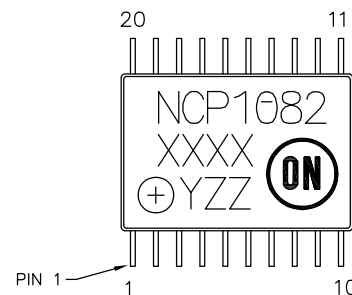

NCP1082 = Specific Device Code
XXXX = Date Code
Y = Assembly Location
ZZ = Traceability Code

ORDERING INFORMATION

See detailed ordering and shipping information in the package dimensions section on page 2 of this data sheet.

NCP1082

DC-DC Converter Controller

- Current Mode Control
- Supports Isolated and Non-isolated DC-DC Converter Applications
- Internal Voltage Regulators
- Wide Duty Cycle Range with Internal Slope Compensation Circuitry
- Programmable Oscillator Frequency
- Programmable Soft-start Time

PIN DIAGRAM

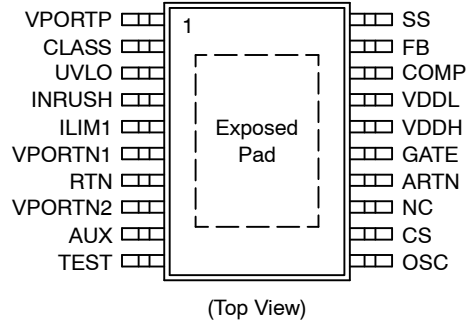

Ordering Information

Part Number	Package	Shipping Configuration†	Temperature Range
NCP1082DEG	TSSOP-20 EP (Pb-Free)	74 units / Tube	-40°C to 85°C
NCP1082DER2G	TSSOP-20 EP (Pb-Free)	2500 / Tape & Reel	-40°C to 85°C

†For information on tape and reel specifications, including part orientation and tape sizes, please refer to our Tape and Reel Packaging Specification Brochure, BRD8011/D.

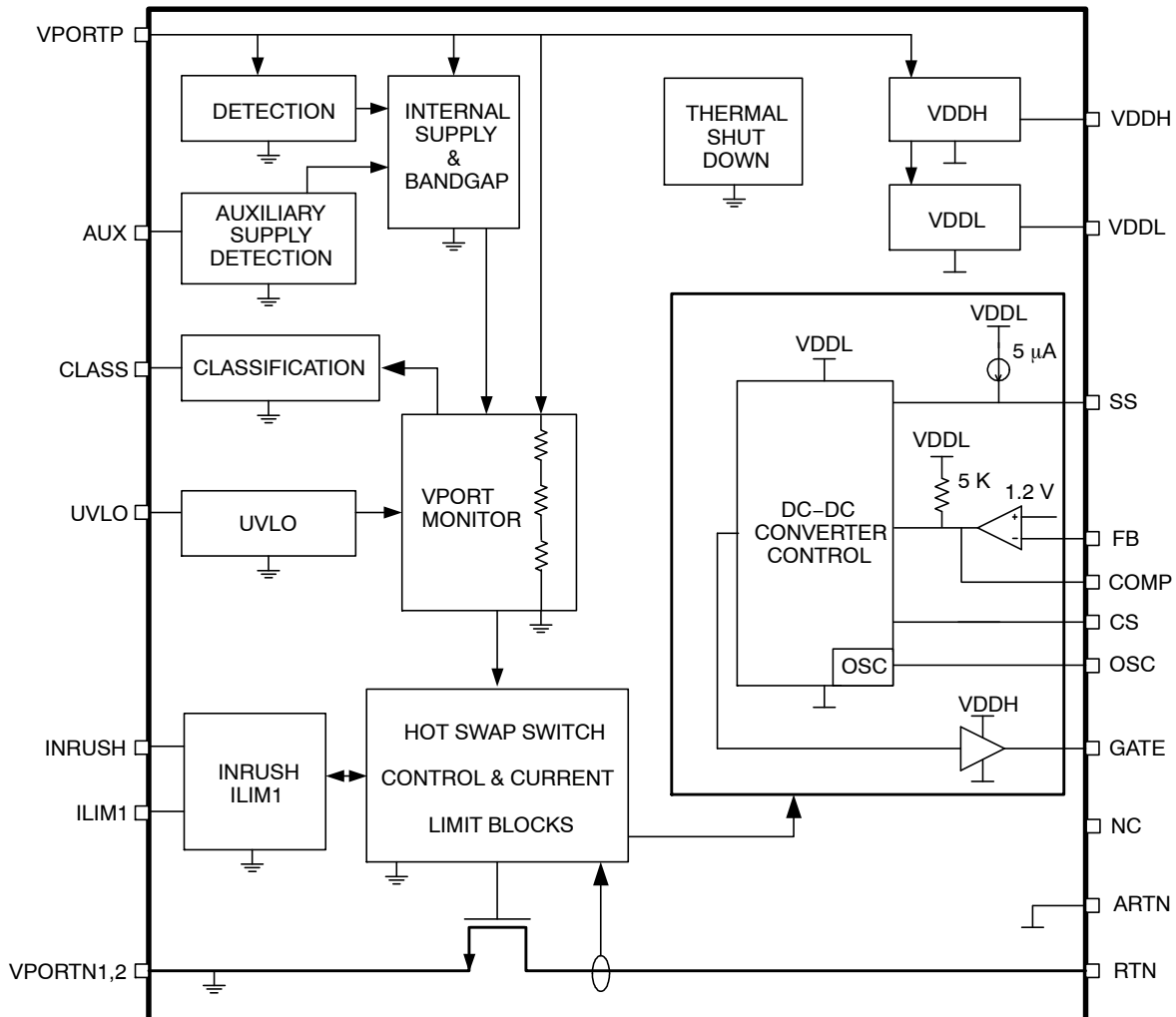

Figure 1. NCP1082 Block Diagram

NCP1082

Simplified Application Diagrams

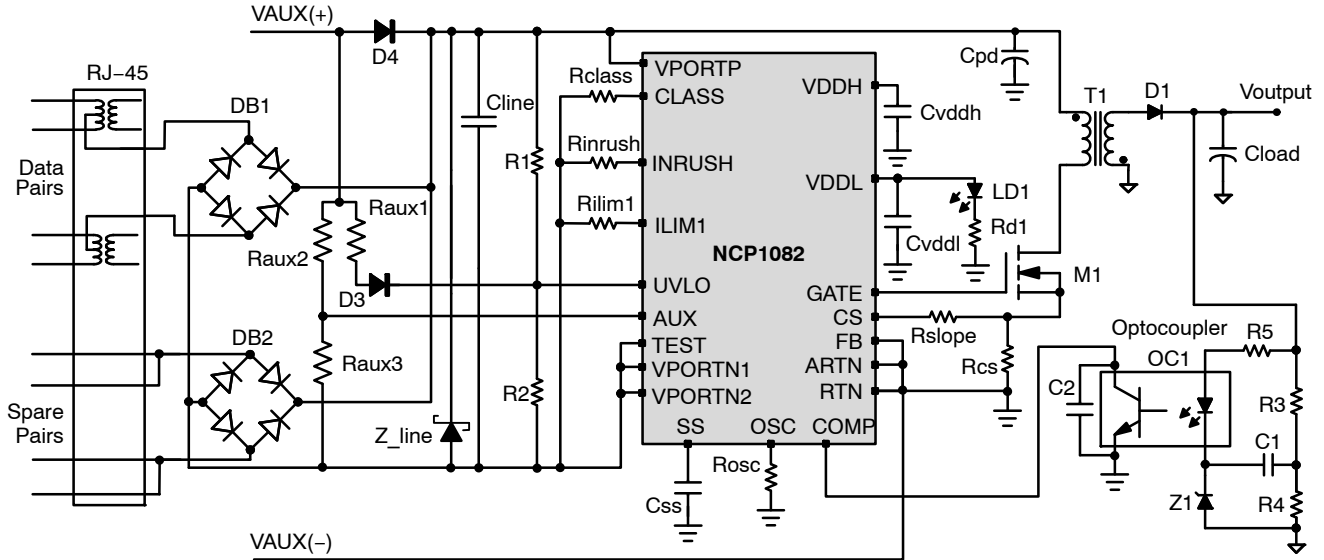

Figure 2. Isolated Fly-back Converter with Rear Auxiliary Support

Figure 2 shows the integrated PoE-PD switch and DC-DC controller configured to work in a fully isolated application. The output voltage regulation is accomplished with an external opto-coupler and a shunt regulator (Z1).

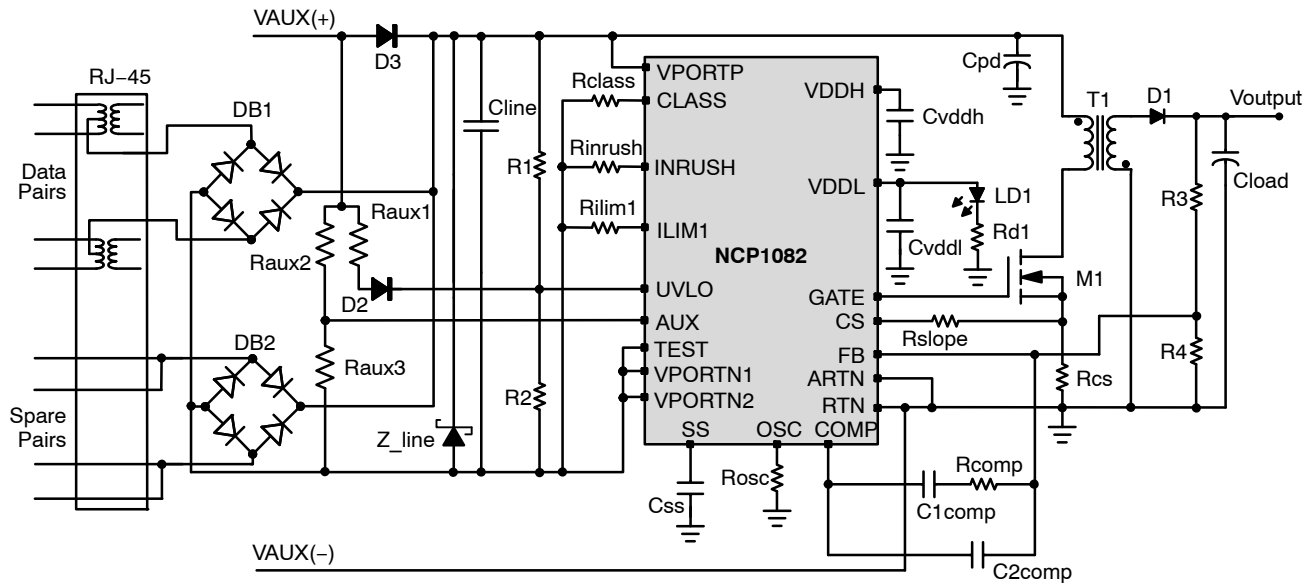

Figure 3. Non-Isolated Fly-back Converter with Rear Auxiliary Support

Figure 3 shows the integrated PoE-PD and DC-DC controller configured in a non-isolated fly-back configuration. A compensation network is inserted between the FB and the COMP pin for overall stability of the feedback loop.

Simplified Application Diagrams

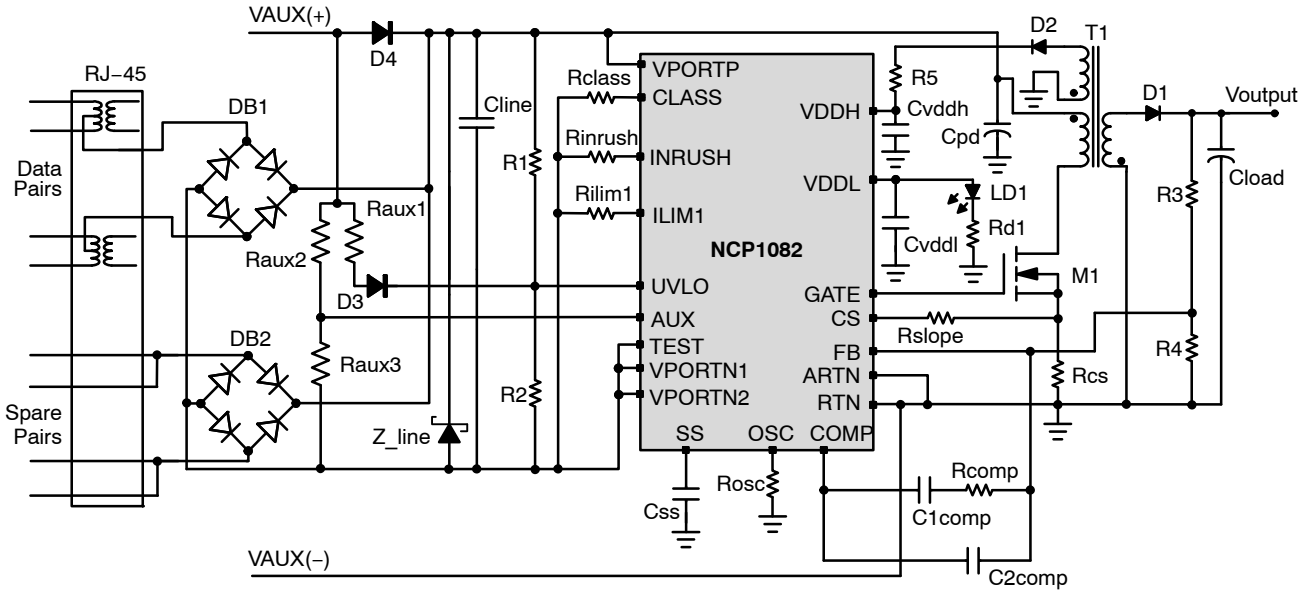

Figure 4. Non-Isolated Fly-back with Extra Winding and Rear Auxiliary Support

Figure 4 shows the same non-isolated fly-back configuration as Figure 3, but adds a 12 V auxiliary bias winding on the transformer to provide power to the NCP1082 DC-DC controller via its VDDH pin. This topology shuts off the current flowing from VPORPTP to VDDH and therefore reduces the internal power dissipation of the PD, resulting in higher overall power efficiency.

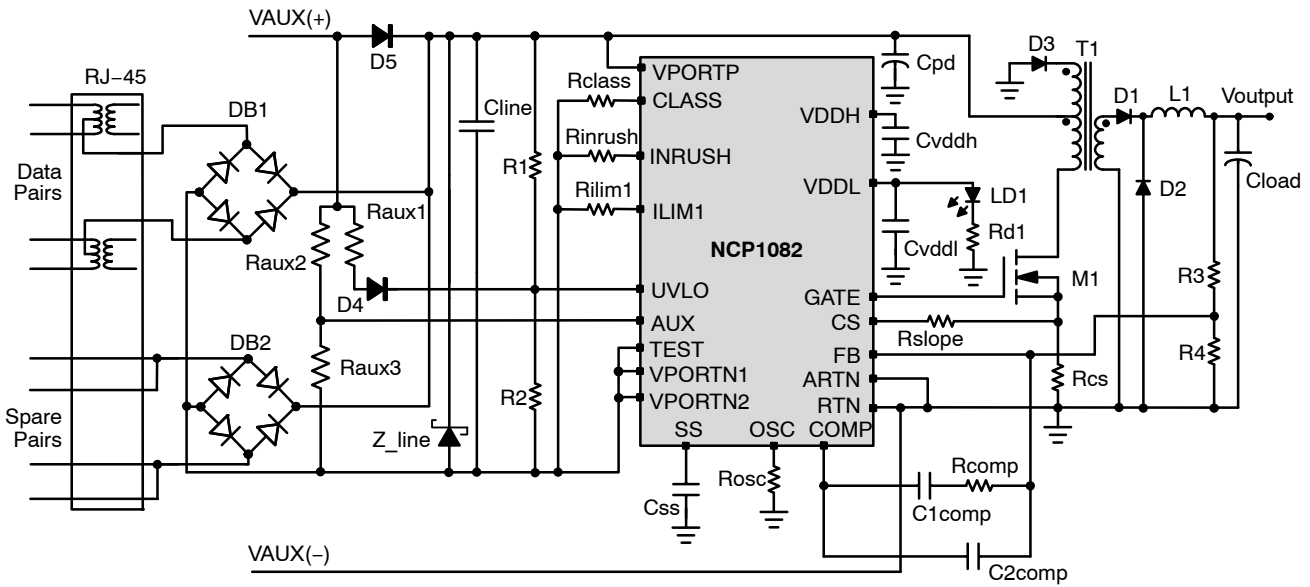

Figure 5. Non-Isolated Forward Converter with Rear Auxiliary Support

Figure 5 shows the NCP1082 used in a non-isolated forward topology.

NCP1082

Table 1. Pin Descriptions

Name	Pin No.	Type	Description
VPORTP	1	Supply	Positive input power. Voltage with respect to VPORTN _{1,2}
VPORTN1 VPORTN2	6,8	Ground	Negative input power. Connected to the source of the internal pass-switch.
RTN	7	Ground	DC-DC controller power return. Connected to the drain of the internal pass-switch. It must be connected to ARTN. This pin is also the drain of the internal pass-switch.
ARTN	14	Ground	DC-DC controller ground pin. Must be connected to RTN as a single point ground connection for improved noise immunity.
VDDH	16	Supply	Output of the 9 V LDO internal regulator. Voltage with respect to ARTN. Supplies the internal gate driver. VDDH must be bypassed to ARTN with a 1 μ F or 2.2 μ F ceramic capacitor with low ESR.
VDDL	17	Supply	Output of the 3.3 V LDO internal regulator. Voltage with respect to ARTN. This pin can be used to bias an external low-power LED (1 mA max.) connected to ARTN, and can also be used to add extra biasing current in the external opto-coupler. VDDL must be bypassed to ARTN with a 330 nF or 470 nF ceramic capacitor with low ESR.
CLASS	2	Input	Classification current programming pin. Connect a resistor between CLASS and VPORTN _{1,2} .
INRUSH	4	Input	Inrush current limit programming pin. Connect a resistor between INRUSH and VPORTN _{1,2} .
ILIM1	5	Input	Operational current limit programming pin. Connect a resistor between ILIM1 and VPORTN _{1,2} .
UVLO	3	Input	DC-DC controller under-voltage lockout input. Voltage with respect to VPORTN _{1,2} . Connect a resistor-divider from VPORTP to UVLO to VPORTN _{1,2} to set an external UVLO threshold.
GATE	15	Output	DC-DC controller gate driver output pin.
OSC	11	Input	Internal oscillator frequency programming pin. Connect a resistor between OSC and ARTN.
NC	13		No connect pin, must not be connected.
COMP	18	I/O	Output of the internal error amplifier of the DC-DC controller. COMP is pulled-up internally to VDDL with a 5 k Ω resistor. In isolated applications, COMP is connected to the collector of the opto-coupler. Voltage with respect to ARTN.
FB	19	Input	DC-DC controller inverting input of the internal error amplifier. In isolated applications, the pin should be strapped to ARTN to disable the internal error amplifier.
CS	12	Input	Current-sense input for the DC-DC controller. Voltage with respect to ARTN.
SS	20	Input	Soft-start input for the DC-DC controller. A capacitor between SS and ARTN determines the soft-start timing.
AUX	9	Input	When the pin is pulled up, the IEEE detection mode is disabled and the device can be supplied by an auxiliary supply. Voltage with respect to VPORTN _{1,2} . Connect the pin to the auxiliary supply through a resistor divider.
TEST	10	Input	Digital test pin must always be connected to VPORTN _{1,2} .
EP			Exposed pad. Connected to VPORTN _{1,2} ground.

NCP1082

Table 2. Absolute Maximum Ratings

Symbol	Parameter	Min.	Max.	Units	Conditions
VPORTP	Input power supply	-0.3	72	V	Voltage with respect to VPORTN _{1,2}
RTN ARTN	Analog ground supply 2	-0.3	72	V	Pass-switch in off-state (Voltage with respect to VPORTN _{1,2})
VDDH	Internal regulator output	-0.3	17	V	Voltage with respect to ARTN
VDDL	Internal regulator output	-0.3	3.6	V	Voltage with respect to ARTN
CLASS	Analog output	-0.3	3.6	V	Voltage with respect to VPORTN _{1,2}
INRUSH	Analog output	-0.3	3.6	V	Voltage with respect to VPORTN _{1,2}
ILIM1	Analog output	-0.3	3.6	V	Voltage with respect to VPORTN _{1,2}
UVLO	Analog input	-0.3	3.6	V	Voltage with respect to VPORTN _{1,2}
OSC	Analog output	-0.3	3.6	V	Voltage with respect to ARTN
COMP	Analog input / output	-0.3	3.6	V	Voltage with respect to ARTN
FB	Analog input	-0.3	3.6	V	Voltage with respect to ARTN
CS	Analog input	-0.3	3.6	V	Voltage with respect to ARTN
SS	Analog input	-0.3	3.6	V	Voltage with respect to ARTN
NC	Open pin				
AUX	Analog input	-0.3	3.6	V	Voltage with respect to VPORTN _{1,2}
TEST	Digital input	-0.3	3.6	V	Voltage with respect to VPORTN _{1,2}
T _a	Ambient temperature	-40	85	°C	
T _j	Junction temperature	-	150	°C	
T _j -TSD	Junction temperature (Note 1)	-	175	°C	Thermal shutdown condition
T _{stg}	Storage Temperature	-55	150	°C	
T _{θJA}	Thermal Resistance, Junction to Air (Note 2)		37.6	°C/W	Exposed pad connected to VPORTN _{1,2} ground
ESD-HBM	Human Body Model	3.5	-	kV	per MIL-STD-883, Method 3015
ESD-CDM	Charged Device Model	750	-	V	
ESD-MM	Machine Model	300	-	V	
LU	Latch-up	±200	-	mA	per JEDEC Standard JESD78
ESD-SYS	System ESD (contact/air) (Note 3)	8/15	-	kV	

Stresses exceeding Maximum Ratings may damage the device. Maximum Ratings are stress ratings only. Functional operation above the Recommended Operating Conditions is not implied. Extended exposure to stresses above the Recommended Operating Conditions may affect device reliability.

1. T_j-TSD allowed during error conditions only. It is assumed that this maximum temperature condition does not occur more than 1 hour cumulative during the useful life for reliability reasons.
2. Mounted on a 1S2P (3 layer) test board with copper coverage of 25 percent for the signal layers and 90 percent copper coverage for the inner planes at an ambient temperature of 85°C in still air. Refer to JEDEC JESD51-7 for details.
3. Surges per EN61000-4-2, 1999 applied between RJ-45 and output ground and between adapter input and output ground of the demo board. The specified values are the test levels and not the failure levels.

Recommended Operating Conditions

Operating conditions define the limits for functional operation and parametric characteristics of the device. Note that the functionality of the device outside the operating conditions described in this section is not warranted. Operating outside the recommended operating conditions for extended periods of time may affect device reliability.

All values concerning the DC–DC controller, VDDH and VDDL blocks are with respect to ARTN. All others are with respect to VPORNTN_{1,2} (unless otherwise noted).

Table 3. Operating Conditions

Symbol	Parameter	Min.	Typ.	Max.	Units	Conditions
INPUT SUPPLY						
VPORT	Input supply voltage	0		57	V	VPORT = VPORTP – VPORNTN _{1,2}

SIGNATURE DETECTION

Vsignature	Input supply voltage signature detection range	1.4		9.5	V	
Rsignature	Signature resistance (Note 4)	23.75		26.25	kΩ	
Offset_current	I_VportP + I_Rtn	–	1.8	5	μA	VPORTP = RTN = 1.4 V
Sleep_current	I_VportP + I_Rtn	–	15	25	μA	VPORTP = RTN = 9.5 V

CLASSIFICATION

Vcl	Input supply voltage classification range	13		20.5	V	
Iclass0	Class 0: Rclass 10 kΩ (Note 5)	0	–	4	mA	Iclass0 = I_VportP + I_Rdet
Iclass1	Class 1: Rclass 130 Ω (Note 5)	9	–	12	mA	Iclass1 = I_VportP + I_Rdet
Iclass2	Class 2: Rclass 69.8 Ω (Note 5)	17	–	20	mA	Iclass2 = I_VportP + I_Rdet
Iclass3	Class 3: Rclass 44.2 Ω (Note 5)	26	–	30	mA	Iclass3 = I_VportP + I_Rdet
Iclass4	Class 4: Rclass 30.9 Ω (Note 5)	36	–	44	mA	Iclass4 = I_VportP + I_Rdet
IDC _{class}	Internal current consumption during classification (Note 6)	–	600	–	μA	For information only

UVLO

Vuvlo_on	Default turn on voltage (VportP rising)		38	40	V	UVLO pin tied to VPORNTN _{1,2}
Vuvlo_off	Default turn off voltage (VportP falling)	29.5	32	–	V	UVLO pin tied to VPORNTN _{1,2}
Vhyst_int	UVLO internal hysteresis	–	6	–	V	UVLO pin tied to VPORNTN _{1,2}
Vuvlo_pr	UVLO external programming range	13	–	50	V	UVLO pin connected to the resistor divider (R1 & R2) AUX pin tied to VPORNTN _{1,2} For information only
Vuvlo_pr_aux	UVLO external programming VPORT range with low auxiliary supply support	8.5	–	18	V	UVLO & AUX pins configured for auxiliary supply support
Vhyst_ext	UVLO external hysteresis	–	15	–	%	UVLO pin connected to the resistor divider (R1 & R2)
Uvlo_Filter	UVLO on/off filter time	–	90	–	μS	For information only

AUXILIARY SUPPLY OPERATION – INPUT SUPPLY

Vaux_min1	VPORTP–ARTN voltage at startup (required for VDDH > VDDH_Por_R)	8.7	–	–	V	VAUX rising – No external load on VDDL & VDDH
Vaux_min2	VPORTP–ARTN voltage during PWM operation (required for VDDH > VDDH_Por_F)	8.5	–	–	V	Voltage with respect to Ivdld_load1 & Ivdhd_load1 for the load current conditions

- Test done according to the IEEE 802.3af 2 Point Measurement. The minimum probe voltages measured at the PoE–PD are 1.4 V and 2.4 V, and the maximum probe voltages are 8.5 V and 9.5 V.
- Measured with an external Rdet of 25.5 kΩ between VPORTP and VPORNTN_{1,2}, and for 13 V < VPORT < 20.5 V (with VPORT = VPORTP – VPORNTN_{1,2}).
- This typical current excludes the current in the Rclass and Rdet external resistors.

Table 3. Operating Conditions

Symbol	Parameter	Min.	Typ.	Max.	Units	Conditions
AUXILIARY SUPPLY OPERATION – AUX PIN						
AUX_threshold	AUX pin internal threshold	0.2	–	1.5	V	Voltage with respect to VPORTN _{1,2}
AUX_bias_min	Minimum Voltage required on the AUX pin for low auxiliary supply operation	1.5	–	–	V	Defined at VPORT = 8.5 V, Voltage with respect to VPORTN _{1,2}
AUX_bias_max	Maximum Voltage allowed on the AUX pin	–	–	3.3	V	Voltage with respect to VPORTN _{1,2}
AUX_res_ladder	Resistor ladder value on AUX pin	–	–	25	kΩ	Between VAUX supply & VPORTN _{1,2}
AUXILIARY SUPPLY OPERATION – VDDL REGULATOR						
Ivddl_load1	Current load on the VDDL pin with VPORTP – ARTN = 8.5 V (Notes 7 and 8)	–	–	1	mA	Ivddh_load + Ivddl_load < 4.5 mA
Ivddl_load2	Current load on the VDDL pin with VPORTP – ARTN > 12.5 V (Notes 7 and 8)	–	–	2.25	mA	Ivddh_load + Ivddl_load < 10 mA
AUXILIARY SUPPLY OPERATION – VDDH REGULATOR						
Ivddh_load1	Current load on the VDDH regulator with VPORTP – ARTN = 8.5 V (Notes 7 and 8)	–	–	4.5	mA	Ivddh_load + Ivddl_load < 4.5 mA
Ivddh_load2	Current load on the VDDH regulator with VPORTP – ARTN > 12.5 V (Notes 7 and 8)	–	–	10	mA	Ivddh_load + Ivddl_load < 10 mA
PASS-SWITCH AND CURRENT LIMITS						
Ron	Pass-switch Rds-on	–	0.6	1.2	Ω	Max Ron specified at Tj = 130°C
I_Rinrush1	Rinrush = 150 kΩ (Note 9)	95	125	155	mA	Measured at RTN–VPORTN _{1,2} = 3 V
I_Rinrush2	Rinrush = 57.6 kΩ (Note 9)	260	310	360	mA	Measured at RTN–VPORTN _{1,2} = 3 V
I_Rilim1	Rilim1 = 84.5 kΩ (Note 9)	450	510	570	mA	Current limit threshold
INRUSH AND ILIM1 CURRENT LIMIT TRANSITION						
Vds_pgood	VDS required for power good status	0.8	1	1.2	V	RTN–VPORTNx falling; voltage with respect to VPORTN _{1,2}
Vds_pgood_hyst	VDS hysteresis required for power good status	–	8.2	–	V	Voltage with respect to VPORTN _{1,2}

- Ivddl_load = current flowing out of the VDDL pin.
Ivddh_load = current flowing out of the VDDH pin + current delivered to the Gate Driver (function of the frequency, VDDH voltage & MOSFET gate capacitance).
- See Figures 6 and 7 for specifications on the load current at lower or higher VPORTP-ARTN voltages. In case the application requires more current capability on VDDL and VDDH, it is recommended to externally supply the VDDH pin with a bias winding from the transformer or to add a diode between VAUX(+) and VDDH pin (verify the VAUX voltage does not exceed the VDDH voltage range).
- The current value corresponds to the PoE–PD input current (the current flowing in the external Rdet and the quiescent current of the device are included).

NCP1082

Table 3. Operating Conditions

Symbol	Parameter	Min.	Typ.	Max.	Units	Conditions
VDDH REGULATOR						
VDDH_reg	Regulator output voltage (Notes 10 and 11)	8.4	9	9.6	V	Ivddh_load + Ivddl_load < 10 mA with Ivddl_load < 2.25 mA and 12.5 V < VPORTP – ARTN < 57 V
VDDH_Off	Regulator turn-off voltage	–	VDDH_reg + 0.5 V	–	V	For information only
VDDH_lim	VDDH regulator current limit (Notes 10 and 11)	13	–	26	mA	
VDDH_Por_R	VDDH POR level (rising)	7.3	–	8.3	V	
VDDH_Por_F	VDDH POR level (falling)	6	–	7	V	
VDDH_ovlo	VDDH over-voltage level (rising)	16	–	18.5	V	
VDDL REGULATOR						
VDDL_reg	Regulator output voltage (Notes 10 and 11)	3.05	3.3	3.55	V	Ivddl_load < 2.25 mA with Ivddh_load + Ivddl_load < 10 mA and 12.5 V < VPORTP – ARTN < 57 V
VDDL_Por_R	VDDL POR level (rising)	VDDL – 0.2	–	VDDL – 0.02	V	
VDDL_Por_F	VDDL POR level (falling)	2.5	–	2.9	V	
GATE DRIVER						
Gate_Tr	GATE rise time (10–90%)	–	–	50	ns	Cload = 2 nF, VDDHreg = 9 V
Gate_Tf	GATE fall time (90–10%)	–	–	50	ns	Cload = 2 nF, VDDHreg = 9 V
PWM COMPARATOR						
VCOMP	COMP control voltage range	1.3	–	3	V	For information only
ERROR AMPLIFIER						
Vbg_fb	Reference voltage	1.15	1.2	1.25	V	Voltage with respect to ARTN
Av_ol	DC open loop gain	–	80	–	dB	For information only
GBW	Error amplifier GBW	1	–	–	MHz	For information only
SOFT-START						
Vss	Soft-start voltage range	–	1.15	–	V	
Vss_r	Soft-start low threshold (rising edge)	0.35	0.45	0.55	V	
Iss	Soft-start source current	3	5	7	μA	
CURRENT LIMIT COMPARATOR						
CStH	CS threshold voltage	324	360	396	mV	
Tblank	Blanking time	–	100	–	nS	For information only

10. Power dissipation must be considered. Load on VDDH and VDDL must be limited especially if VDDH is not powered by an auxiliary winding.

11. Ivddl_load = current flowing out of the VDDL pin.

Ivddh_load = current flowing out of the VDDH pin + current delivered to the Gate Driver (function of the frequency, VDDH voltage & MOSFET gate capacitance).

Table 3. Operating Conditions

Symbol	Parameter	Min.	Typ.	Max.	Units	Conditions
OSCILLATOR						
DutyC	Maximum duty cycle	–	80%	–		Fixed internally
Frang	Oscillator frequency range	100	–	500	kHz	
F_acc	Oscillator frequency accuracy		±25		%	
CURRENT CONSUMPTION						
IvportP ₁	VPORTP internal current consumption (Note 12)	–	2.5	3.5	mA	DC–DC controller off
IvportP ₂	VPORTP internal current consumption (Note 13)	–	4.7	6.5	mA	DC–DC controller on
THERMAL SHUTDOWN						
TSD	Thermal shutdown threshold	150	–	–	°C T _j	T _j = junction temperature
Thyst	Thermal hysteresis	–	15	–	°C T _j	T _j = junction temperature
THERMAL RATINGS						
T _a	Ambient temperature	–40	–	85	°C	
T _j	Junction temperature	–	–	125 150	°C °C	Parametric values guaranteed Max 1000 hours

12. Conditions

- a. No current through the pass-switch
- b. DC–DC controller inactive (SS shorted to RTN)
- c. No external load on VDDH and VDDL
- d. VPORTP = 57 V

13. Conditions

- a. No current through the pass-switch
- b. Oscillator frequency = 100 kHz
- c. No external load on VDDH and VDDL
- d. Aux winding not used
- e. 2 nF on GATE, DC–DC controller enabled
- f. VPORTP = 57 V

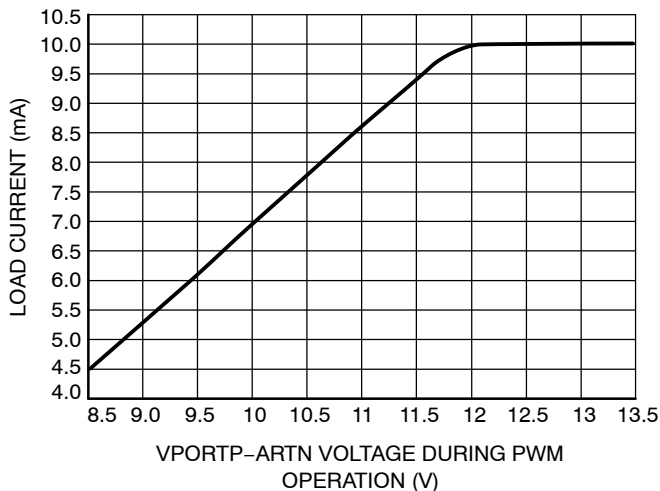

Figure 6. (Ivddl_load)max with Auxiliary Supply Operation

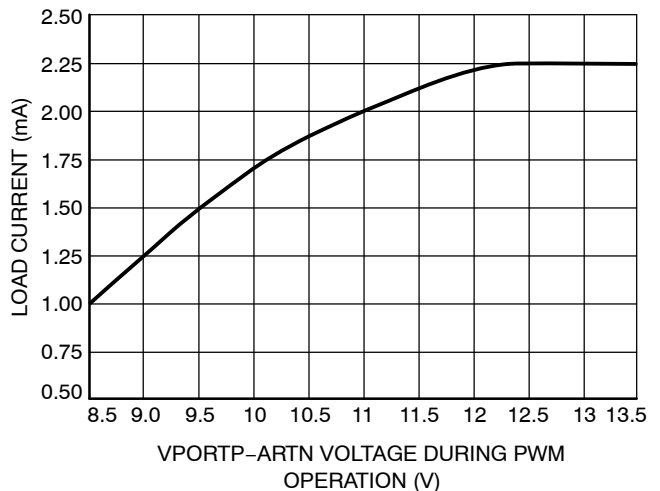

Figure 7. (Ivddh_load+Ivddl_load)max with Auxiliary Supply Operation

Description of Operation

Powered Device Interface

The PD interface portion of the NCP1082 supports the IEEE 802.3af defined operating modes: detection signature, current source classification, inrush and operating current limits. In order to give more flexibility to the user and also to keep control of the power dissipation in the NCP1082, both current limits are configurable. The device enters operation once its programmable Vuvlo_on threshold is reached, and operation ceases when the supplied voltage falls below the Vuvlo_off threshold. Sufficient hysteresis and Uvlo filter time are provided to avoid false power on/off cycles due to transient voltage drops on the cable.

Detection

During the detection phase, the incremental equivalent resistance seen by the PSE through the cable must be in the IEEE 802.3af standard specification range (23.75 kΩ to 26.25 kΩ) for a PSE voltage from 2.7 V to 10.1 V. In order to compensate for the non-linear effect of the diode bridge and satisfy the specification at low PSE voltage, the NCP1082 presents a suitable impedance in parallel with the 25.5 kΩ Rdet external resistor. For some types of diodes (especially Schottky diodes), it may be necessary to adjust this external resistor.

When the Detection_Off level is detected (typically 11.5 V) on VPORTP, the NCP1082 turns on its internal 3.3 V regulator and biasing circuitry in anticipation of the classification phase as the next step.

Classification

Once the PSE device has detected the PD device, the classification process begins. In classification, the PD regulates a constant current source that is set by the external resistor RCLASS value on the CLASS pin. Figure 8 shows the schematic overview of the classification block. The current source is defined as:

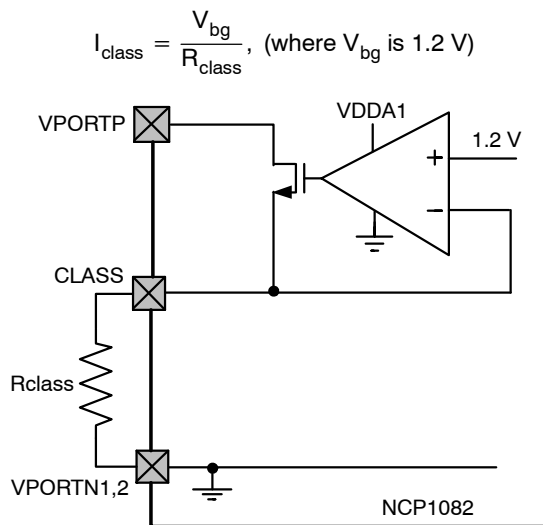

Figure 8. Classification Block Diagram

Power Mode

When the classification hand-shake is completed, the PSE and PD devices move into the operating mode.

Under Voltage Lock Out (UVLO)

The NCP1082 incorporates an under voltage lock out (UVLO) circuit which monitors the input voltage and determines when to apply power to the DC-DC controller.

To use the default settings for UVLO (see Table 3), the pin UVLO must be connected to VPORTN1,2. In this case the signature resistor has to be placed directly between VPORTP and VPORTN1,2, as shown in Figure 9.

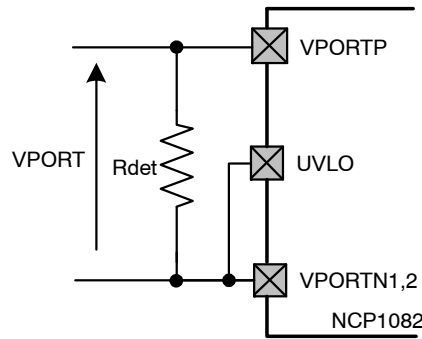

Figure 9. Default UVLO Settings

To define the UVLO threshold externally, the UVLO pin must be connected to the center of an external resistor divider between VPORTP and VPORTN1,2 as shown in Figure 10. The series resistance value of the external resistors must add to 25.5 kΩ and replaces the internal signature resistor.

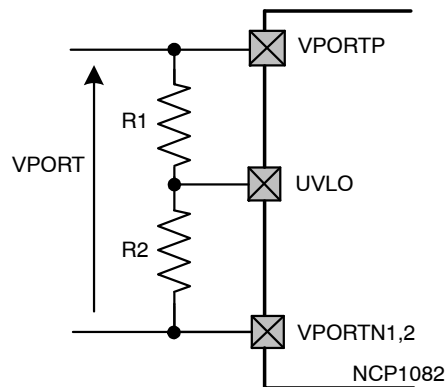

Figure 10. External UVLO Configuration

For a Vuvlo_on desired turn-on voltage threshold, R1 and R2 can be calculated using the following equations:

$$R1 + R2 = R_{det}$$

$$R2 = \frac{1.2}{V_{ulvo_on}} \times R_{det}$$

When using the external resistor divider, the NCP1082 has an external reference voltage hysteresis of 15 percent typical.

Auxiliary Supply Support

To support applications connected to non PoE enabled networks and minimize the bill of materials, the NCP1082 supports drawing power from an external supply. The NCP1082 supports the IEEE 802.3af standard when the PoE capability is available and acts as a regular DC-DC converter when there is no power source on the Ethernet cable as shown in Figure 11.

Auxiliary supply support can be implemented in three ways depending on where the auxiliary supply is injected. The front, rear and direct auxiliary supply configurations are explained in more detail in the application note “NCP1082-3 PoE Auxiliary Supply Applications”.

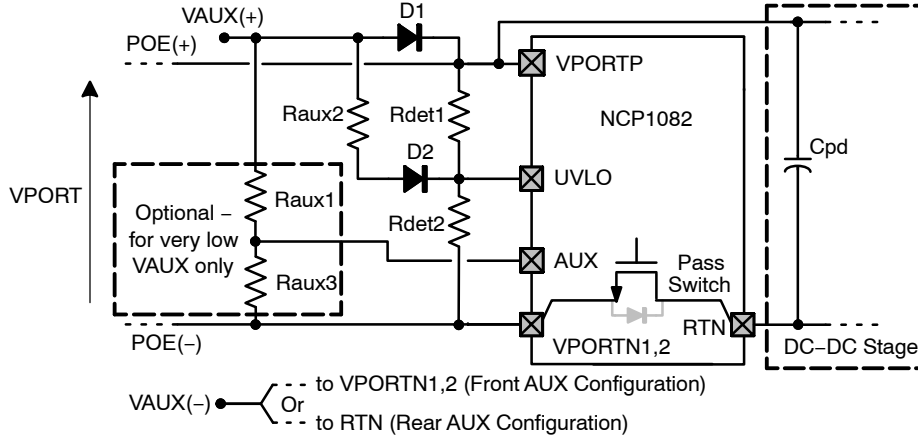

Figure 11. Front and Rear Auxiliary Supply Input with Support for Very Low Input Voltages

When the auxiliary input supply is above 13.5 V, connect the AUX pin to VPORTN_{1,2}. When the auxiliary supply is below 13.5 V (but above 9 V), calculate the voltage dividers Raux1, Raux3 and Raux2, Rdet1, Rdet2 to divide the input voltage to at least 2 V at the UVLO pin and 2 V at the AUX pin using the following formulas. Note the maximum voltage is 3.3 V.

$$R_{aux3} = \frac{R_{aux1} \times V_t}{V_{aux} - V_{dp} - V_t}$$

$$R_{aux2} = \frac{V_{aux} - V_{dp} - V_d - V_t}{\frac{V_t}{845} - \frac{V_{aux} - V_{dp} - V_d - V_t}{24 K}}$$

$$R_{aux1} = 20 K\Omega$$

With

V_d is the voltage drop over the rectifiers and masking diodes (typical 0.6 V), and

V_{dp} = 0.5 V the forward voltage drop of the NCP1082 internal diode, and

V_t is the desired voltage at the AUX pin.

Note that as soon the auxiliary supply is connected the PoE interface (detection and classification) is disabled and does not allow the PD device to be powered from the Ethernet until the auxiliary supply is removed.

If the PoE PD device was drawing the current from the Ethernet cable before the auxiliary supply is connected, the power will continue to be supplied from the Ethernet cable unless the voltage of the auxiliary supply is higher than the Ethernet supply voltage.

Inrush and Operational Current Limitations

The inrush current limit and the operational current limit are programmed individually by an external Rinrush and Rilim1 resistors respectively connected between INRUSH and VPORTN_{1,2}, and between ILIM1 and VPORTN_{1,2} as shown in Figure 12.

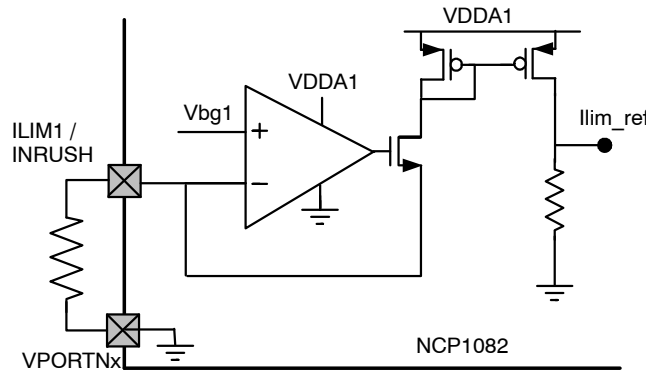

Figure 12. Current Limitation Configuration (Inrush & Ilim1 Pins)

NCP1082

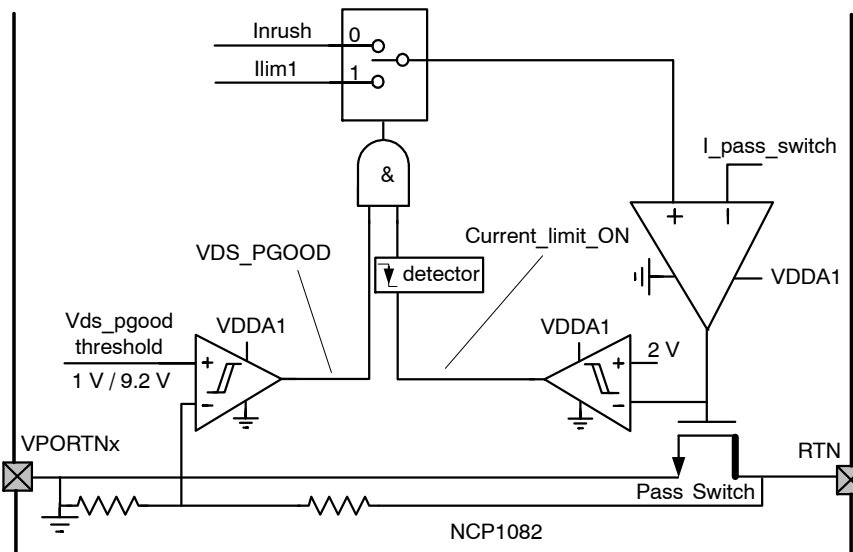

Figure 13. Inrush and Ilim1 Selection Mechanism

When VPORT reaches the UVLO_on level, the Cpd capacitor is charged with the INRUSH current (in order to limit the internal power dissipation of the pass-switch). Once the Cpd capacitor is fully charged, the current limit switches from the inrush current to the operational current level (Ilim1) as shown in Figure 13. This transition occurs when both following conditions are satisfied:

1. The VDS of the pass-switch is below the Vds_pgood low level (1 V typical).
2. The pass-switch is no longer in current limit mode, meaning the gate of the pass-switch is “high” (above 2 V typical).

The operational current limit will stay selected as long as Vds_pgood is true (meaning that RTN-VPORNT_{1,2} is below the high level of Vds_pgood). This mechanism allows a current level transition without any current spike in the pass-switch because the operational current limit (Ilim1) is enabled once the pass-switch is not limiting the current anymore, meaning that the Cpd capacitor is fully charged.

Thermal Shutdown

The NCP1082 includes thermal protection which shuts down the device in case of high power dissipation. Once the thermal shutdown (TSD) threshold is exceeded, following blocks are turned off:

- DC-DC controller
- Pass-switch
- VDDH and VDDL regulators
- CLASS regulator

When the TSD error disappears and if the input line voltage is still above the UVLO level, the NCP1082 automatically restarts with the current limit set in the inrush state, the DC-DC controller is disabled and the C_{ss} (soft-start capacitor) discharged. The DC-DC controller becomes operational as soon as RTN-VPORNT_{1,2} is below the Vds_pgood threshold.

NCP1082

DC-DC Converter Controller

The NCP1082 implements a current mode DC-DC converter controller which is illustrated in Figure 14.

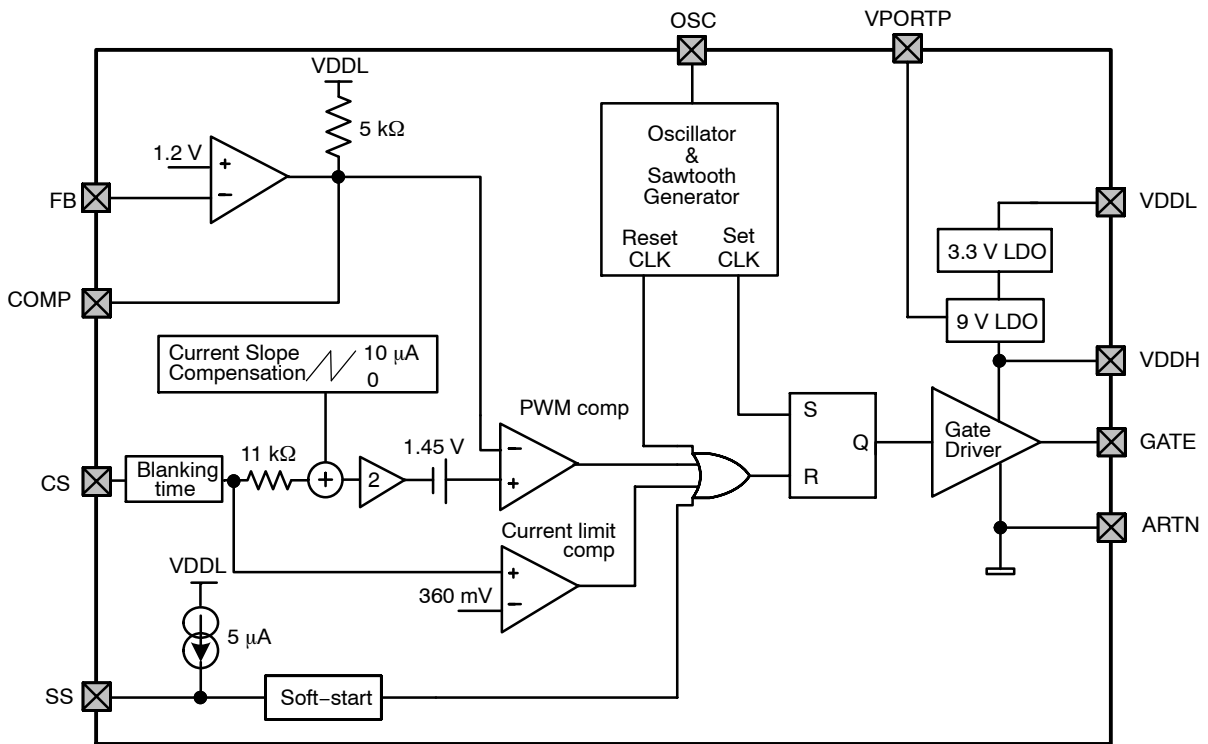

Figure 14. DC-DC Controller Block Diagram

Internal VDDH and VDDL Regulators and Gate Driver

An internal linear regulator steps down the VPORTP voltage to a 9 V output on the VDDH pin. VDDH supplies the internal gate driver circuit which drives the GATE pin and the gate of the external power MOSFET. The NCP1082 gate driver supports an external MOSFET with high V_{th} and high input gate capacitance. A second LDO regulator steps down the VDDH voltage to a 3.3 V output on VDDL. VDDL powers the analog circuitry of the DC-DC controller.

In order to prevent uncontrolled operations, both regulators include power-on-reset (POR) detectors which prevent the DC-DC controller from operating when either VDDH or VDDL is too low. In addition, an over-voltage lockout (OVLO) on the VDDH supply disables the gate driver in case of an open-loop converter with a configuration using the bias winding of the transformer (see Figure 4).

Both VDDH and VDDL regulators turn on as soon as VPORT reaches the V_{uvlo_on} threshold.

Error Amplifier

In non-isolated converter topologies, the high gain internal error amplifier of the NCP1082 and the internal 1.2 V reference voltage regulate the DC-DC output voltage. In this configuration, the feedback loop compensation network should be inserted between the FB and COMP pins as shown in Figures 3, 4 and 5.

In isolated topologies the error amplifier is not used because it is already implemented externally with the shunt regulator on the secondary side of the DC-DC controller (see Figure 2). Therefore the FB pin must be strapped to ARTN and the output transistor of the opto-coupler has to be connected on the COMP pin where an internal 5 kΩ pull-up resistor is tied to the VDDL supply (see Figure 14).

Soft-Start

The soft-start function provided by the NCP1082 allows the output voltage to ramp up in a controlled fashion, eliminating output voltage overshoot. This function is programmed by connecting a capacitor C_{ss} between the SS and ARTN pins.

While the DC-DC controller is in POR, the capacitor C_{ss} is fully discharged. After coming out of POR, an internal current source of 5 µA typically starts charging the capacitor C_{ss} to initiate soft-start. When the voltage on SS pin has reached 0.45 V (typical), the gate driver is enabled and DC-DC operation starts with a duty cycle limit which increases with the SS pin voltage. The soft-start function is finished when the SS pin voltage goes above 1.6 V for which the duty cycle limit reaches its maximum value of 80 percent.

Soft-start can be programmed by using the following equation:

$$t_{ss}(ms) = 0.23 \times C_{ss}(nf)$$

NCP1082

Current Limit Comparator

The NCP1082 current limit block behind the CS pin senses the current flowing in the external MOSFET for current mode control and cycle-by-cycle current limit. This is performed by the current limit comparator which, on the CS pin, senses the voltage across the external Rcs resistor located between the source of the MOSFET and the ARTN pin.

The NCP1082 also provides a blanking time function on CS pin which ensures that the current limit and PWM comparators are not prematurely triggered by the current spike that occurs when the switching MOSFET turns on.

Slope Compensation Circuitry

To overcome sub-harmonic oscillations and instability problems that exist with converters running in continuous

conduction mode (CCM) and when the duty cycle is close or above 50 percent, the NCP1082 integrates a current slope compensation circuit. The amplitude of the added slope compensation is typically 110 mV over one cycle.

As an example, for an operating switching frequency of 250 kHz, the internal slope provided by the NCP1082 is 27.5 mV/μA typically.

DC-DC Controller Oscillator

The frequency is configured with the R_{osc} resistor inserted between OSC and ARTN, and is defined by the following equation:

$$R_{\text{OSC}}(\text{k}\Omega) = \frac{38600}{F_{\text{OSC}}(\text{kHz})}$$

The duty cycle limit is fixed internally at 80 percent.

NCP1082

PACKAGE DIMENSIONS

TSSOP-20 EP
CASE 948AB-01
ISSUE O

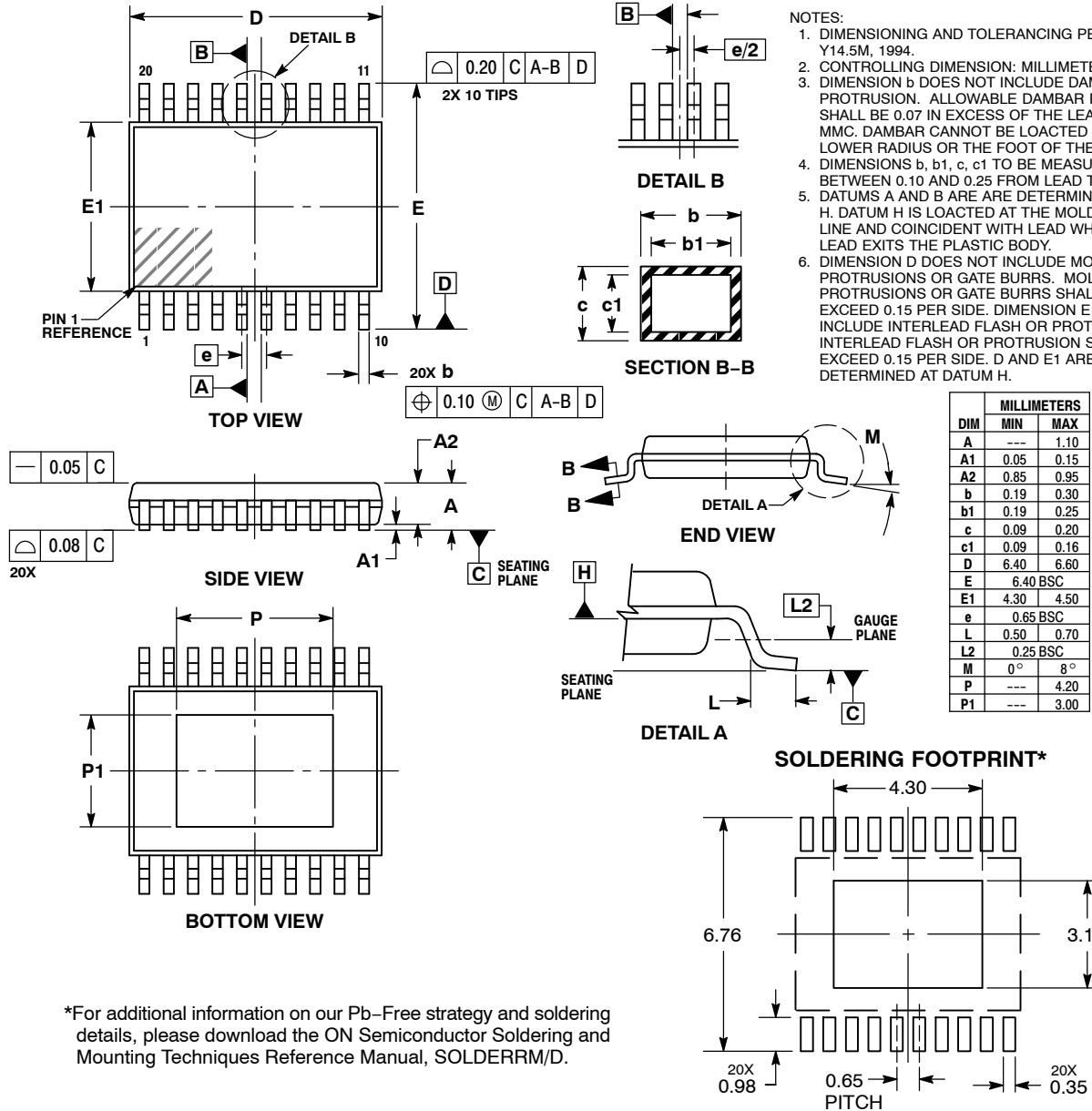

*For additional information on our Pb-Free strategy and soldering details, please download the ON Semiconductor Soldering and Mounting Techniques Reference Manual, SOLDERRM/D.

The product described herein may be covered by one or more US patents pending.

DIMENSIONS: MILLIMETERS

ON Semiconductor and are registered trademarks of Semiconductor Components Industries, LLC (SCILLC). SCILLC reserves the right to make changes without further notice to any products herein. SCILLC makes no warranty, representation or guarantee regarding the suitability of its products for any particular purpose, nor does SCILLC assume any liability arising out of the application or use of any product or circuit, and specifically disclaims any and all liability, including without limitation special, consequential or incidental damages. "Typical" parameters which may be provided in SCILLC data sheets and/or specifications can and do vary in different applications and actual performance may vary over time. All operating parameters, including "Typicals" must be validated for each customer application by customer's technical experts. SCILLC does not convey any license under its patent rights nor the rights of others. SCILLC products are not designed, intended, or authorized for use as components in systems intended for surgical implant into the body, or other applications intended to support or sustain life, or for any other application in which the failure of the SCILLC product could create a situation where personal injury or death may occur. Should Buyer purchase or use SCILLC products for any such unintended or unauthorized application, Buyer shall indemnify and hold SCILLC and its officers, employees, subsidiaries, affiliates, and distributors harmless against all claims, costs, damages, and expenses, and reasonable attorney fees arising out of, directly or indirectly, any claim of personal injury or death associated with such unintended or unauthorized use, even if such claim alleges that SCILLC was negligent regarding the design or manufacture of the part. SCILLC is an Equal Opportunity/Affirmative Action Employer. This literature is subject to all applicable copyright laws and is not for resale in any manner.

PUBLICATION ORDERING INFORMATION

LITERATURE FULFILLMENT:
 Literature Distribution Center for ON Semiconductor
 P.O. Box 5163, Denver, Colorado 80217 USA
Phone: 303-675-2175 or 800-344-3860 Toll Free USA/Canada
Fax: 303-675-2176 or 800-344-3867 Toll Free USA/Canada
Email: orderlit@onsemi.com

N. American Technical Support: 800-282-9855 Toll Free
 USA/Canada
Europe, Middle East and Africa Technical Support:
 Phone: 421 33 790 2910
Japan Customer Focus Center
 Phone: 81-3-5773-3850

ON Semiconductor Website: www.onsemi.com
Order Literature: <http://www.onsemi.com/orderlit>

For additional information, please contact your local Sales Representative